

Product Specification Type Number : M T M C 8 E 2 A 0 L B F *1)				Prepared by M.Hamada	Checked by T.Tanida	Applied by H.Shidooka	Established by K.Kemichi		
Type	Silicon Field Effect Transistors								
Application	Li-ion Battery								
Structure	Gate Resistor installed Dual N-Channel MOS Type								
Outline	WMini8 - F1			Marking			4B		
Absolute Maximum Ratings	VDSS	VGSS	ID	IDp	*2) PD1	*2,*3) PD2	*4) PD3	Tch	Tstg
	20	±12	7.0	42	1.0	1.2	0.4	150	-55 to +150
	(V)	(V)	(A)	(A)	(W)	(W)	(W)	(°C)	(°C)
Electrical characteristics (Ta = 25 °C ±3 °C)									
Item	Symbol	Measuring condition	Limit			Unit			
			min.	typ.	max.				
Drain-Source Voltage	VDSS	ID = 1.0 mA, VGS = 0 V	20			V			
Drain-Source Cutoff Current	IDSS	VDS = 20 V, VGS = 0 V			1.0	μA			
Gate-Source Cutoff Current	IGSS	VGS = ±8.0 V, VDS = 0 V			±10	μA			
Gate Threshold Voltage	Vth	ID = 1.0 mA, VDS = 10 V	0.40	0.85	1.3	V			
Drain Resistance (ON) 1	RDS(ON) 1	ID = 2.0 A, VGS = 4.5 V		15	21	mΩ			
Drain Resistance (ON) 2	RDS(ON) 2	ID = 2.0 A, VGS = 3.7 V		18	25	mΩ			
Drain Resistance (ON) 3	RDS(ON) 3	ID = 2.0 A, VGS = 2.5 V		22	33	mΩ			
Forward Transfer Admittance	Yfs	ID = 1.0 A, VDS = 10 V	3.0			S			
Small-Signal Short-Circuit Input Capacitance	Ciss	VDS = 10 V, VGS = 0 V, f = 1 MHz		1450		pF			
Small-Signal Short-Circuit Output Capacitance	Coss	VDS = 10 V, VGS = 0 V, f = 1 MHz		100		pF			
Small-Signal Reverse Transfer Capacitance	Crss	VDS = 10 V, VGS = 0 V, f = 1 MHz		90		pF			
Turn-on Delay Time	td(on) *5)	VDD = 10 V, VGS = 0 to 4 V, ID = 1.0 A		0.33		μs			
Rise Time	tr *5)	VDD = 10 V, VGS = 0 to 4 V, ID = 1.0 A		0.70		μs			
Turn-off Delay Time	td(off) *5)	VDD = 10 V, VGS = 4 to 0 V, ID = 1.0 A		4.0		μs			
Fall Time	tf *5)	VDD = 10 V, VGS = 4 to 0 V, ID = 1.0 A		2.0		μs			
<p>Note: Measuring methods for transistors are based on JAPANESE INDUSTRIAL STANDARD JIS C 7030.</p> <p style="text-align: center;"><u>Internally connected circuit</u></p> <div style="display: flex; justify-content: space-between;"> <div style="width: 45%;"> <p>*1 Packing: Embossed TX Type (Thermo-compression sealing)</p> <p>*2 Glass epoxy board (25.4 x 25.4 x t0.8 mm) coated with copper foil, which has more than 300mm².</p> <p>*3 t = 10 s</p> <p>*4 Stand-alone (without the board)</p> <p>*5 Refer to test circuit</p> </div> <div style="width: 45%;"> <p>1.Source1 2.Gate1 3.Source2 4.Gate2 5.Drain 6.Drain 7.Drain 8.Drain</p>  <p style="text-align: center;">Rg = 1kΩ</p> </div> </div>									
2007.12.14	-								
Established	Revised								

Product Specification
 Type Number : MTMC8E2A0 LBF

Test circuit

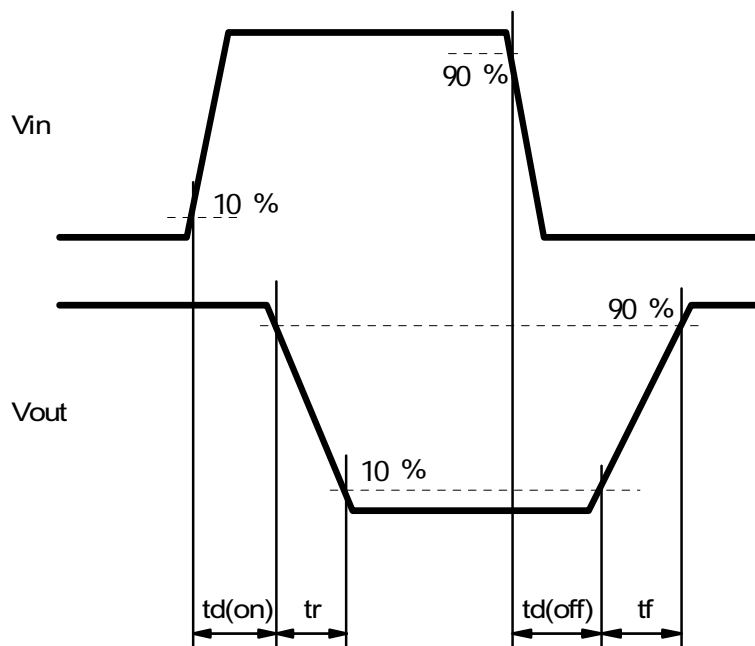
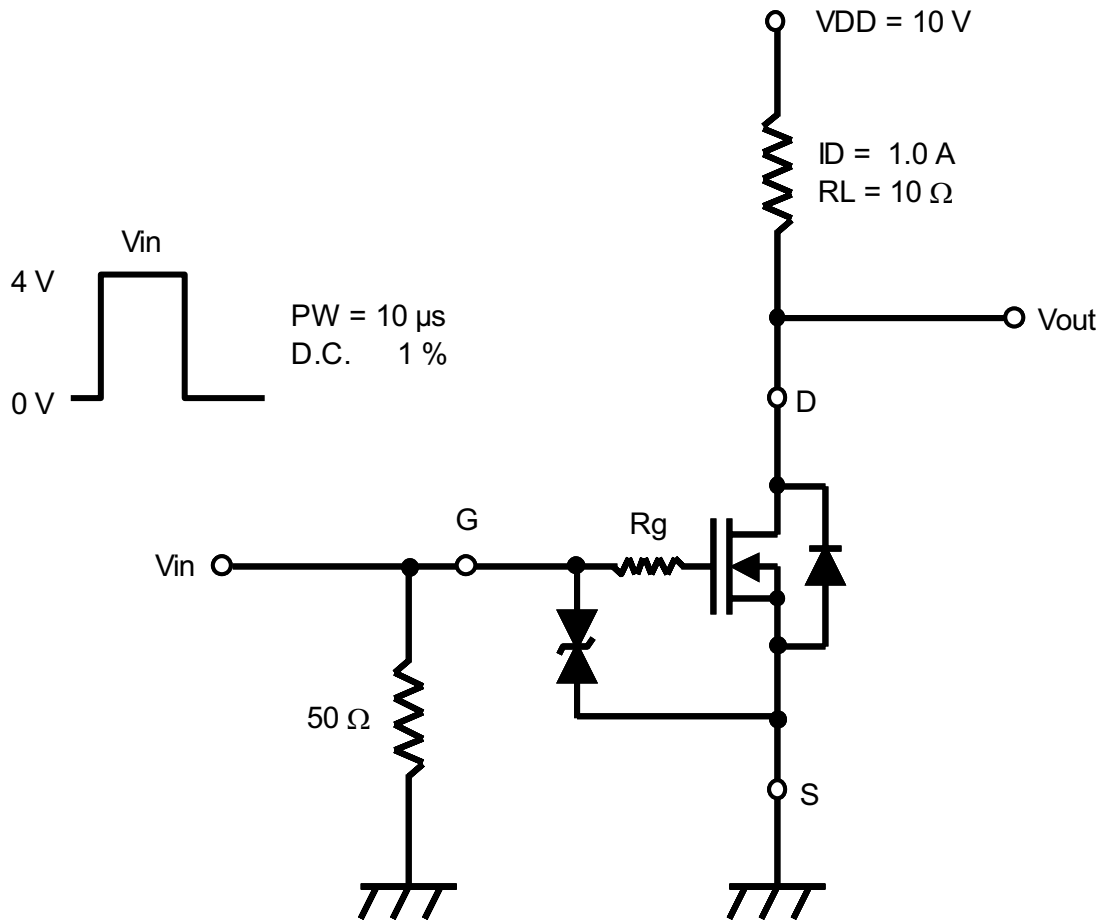

2007.12.14	-
Established	Revised

Product Specification
 Mark Indication
 Type Number : M T M C 8 E 2 A 0 L B F

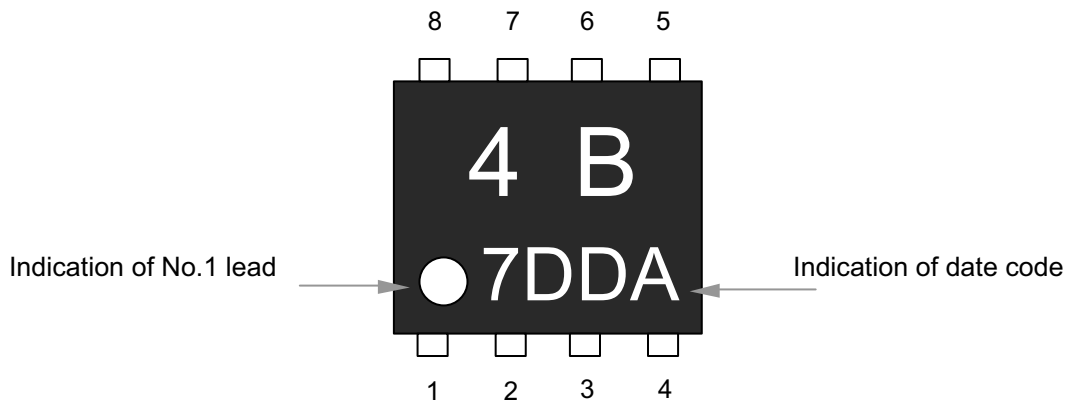

The actual font of product symbol may differ slightly from the font shown in this specification.

Connection

- 1.Source1 5.Drain
- 2.Gate1 6.Drain
- 3.Source2 7.Drain
- 4.Gate2 8.Drain

<<Example of indication of date code>>

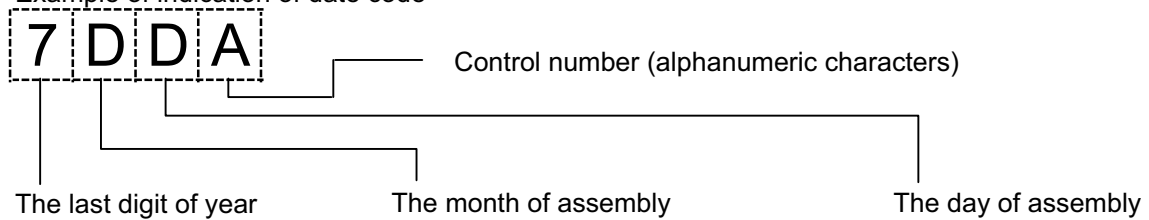

AD2007	7	Jan. to Sep.	1 ~ 9 / 1 to 9
AD2008	8	Oct.	O
AD2009	9	Nov.	N
AD2010	0	Dec.	D

Day	Symbol	Day	Symbol	Day	Symbol
1	1	11	A	21	M
2	2	12	B	22	N
3	3	13	C	23	P
4	4	14	D	24	R
5	5	15	E	25	S
6	6	16	F	26	T
7	7	17	H	27	U
8	8	18	J	28	V
9	9	19	K	29	W
10	0	20	L	30	X
				31	Y

• Factory distinction mark

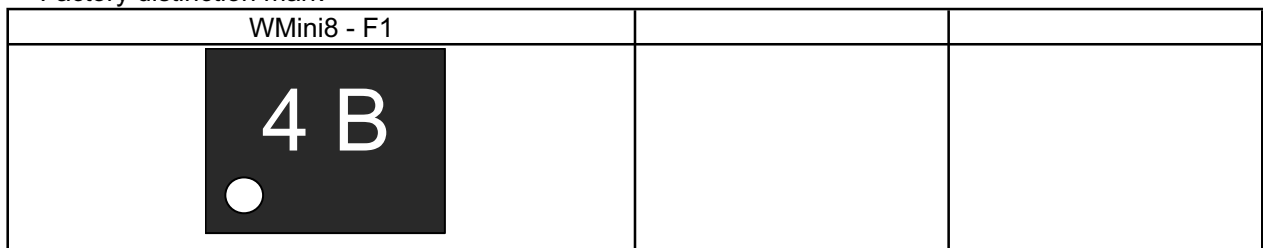

White parts are treated by laser mark.

2007.12.14	-	
Established	Revised	